

→ Series 812



■ MATERIAL



■ SPECIFICATION



1/2" – 2"



– 60°C to + 225°C
depending on version



0,2 – 50 bar
depending on version

neutral



■ EXAMPLES OF USE

For the protection of:

- pressure tanks and
- pressure systems

for air and other neutral, non-poisonous and non-flammable gases which can be freely discharged into the environment.

Please observe plant-specific regulations and use of appropriate valve version and sealing material.

- pneumatic control units
- pressure booster plants air-side
- paint spray shops
- transport- and railway applications
- pneumatic braking systems

Safety valves are set and sealed at the factory.

■ APPROVALS

TÜV Type test approval 2003	D/G
ASME	G
CRN	G
EU type examination	S/G
TSG ZF001-2006	D/G (S/G)
KGS	G
TR ZU 032/2013 - TR ZU 010/2011	D/G (S/G)
Type approval Deutsche Bahn	
Requirements	
AD 2000 Data sheet A2	ASME-Code Sec. VIII Div. 1
DIN EN ISO 4126-1	KGS AA 319
PED 2014/68/EU	

Classification society

DNV	DNV
Lloyd's Register EMEA	LR EMEA
American Bureau of Shipping	ABS
Bureau Veritas	BV
Russian Maritime Register of Shipping	RS
Registro Italiano Navale	RINA

■ MATERIALS

Component	Material	DIN EN	ASME
Inlet body	Brass	CW617N	CW617N
Outlet body	Brass	CW617N	CW617N
Internal parts	Brass / Stainless steel	CW617N / 1.4404	CW617N / 316 L
Spring	Stainless steel	1.4310 / 1.4568	302 / 631
Sealing cap	Stainless steel	1.4301	304

s	Standard	cylindrical form, atmospheric discharge, for air and similar neutral, non-toxic and non-flammable gases that can be freely discharged into the atmosphere.
----------	----------	--

■ MEDIUM

G	gaseous	Air and similar neutral gases
----------	---------	-------------------------------

■ TYPE OF LIFTING MECHANISM

K	Standard with twist-type lifting mechanism	
0	without lifting device	

■ AVAILABLE NOMINAL DIAMETERS AND CONNECTION SIZES

Nominal diameter DN	15	20	25	32	40	50
Inlet	1/2" (15)	3/4" (20)	1" (25)	1 1/4" (32)	1 1/2" (40)	2" (50)
Atmospheric discharge via outlet apertures	■	■	■	■	■	■

■ TYPE OF CONNECTION INLET / OUTLET THREADED CONNECTIONS

m / -	Standard	Male thread BSP-P / -	DIN EN ISO 228-1 / -
BSP-Tm / -		Male thread BSP-T	DIN EN 10226, ISO 7-1 / -
NPT-m / -		Male thread NPT / -	ANSI B1.20.1 / -

■ SEALS

NBR	Nitrile rubber	Elastomere flat seal 0,2 – 30 bar	-30°C to +130°C
FKM	Fluorocarbon	Elastomere flat seal 0,2 – 30 bar	-20°C to +200°C
EPDM	Ethylene propylene diene	Elastomere flat seal 0,2 – 30 bar	-40°C to +170°C
PTFE	Polytetrafluoroethylene	Flat seal 0,2 – 50 bar	-60°C to +225°C

■ NOMINAL DIAMETERS, CONNECTIONS, INSTALLATION DIMENSIONS

Series 812: Connection, installation dimensions, ranges of adjustment							
Nominal diameter	DN	15	20	25	32	40	50
Connection DIN EN ISO 228	G	1/2" (15)	3/4" (20)	1" (25)	1 1/4" (32)	1 1/2" (40)	2" (50)
Installation dimensions in mm	H (H1)	144	177	177	215 (177 ¹)	215 (177 ¹)	282
	H2	137	173	173	212	212	284
	h	12	15	15	22,5	22,5	26
	SW	32	41	41	55	55	80
	d0	14	20	24	31	31	48
Coefficients of flow ISO 4126-1	$c_{w}/K_{dr}(D/G)^2$	0,76	0,8	0,8	0,8	0,8	0,51 ³
Coefficients of flow ASME-Code Sec. VIII Div. 1	$c_w/K_{dr}(D/G)$	0,774	0,774	0,774	0,774	0,774	30,116 ⁴
Weight	kg	0,6	1,3	1,3	2,6	2,6	5,4
Range of adjustment	bar	0,2-50	0,2-50	0,2-50	0,2-50	0,2-50	0,2-30
Range of adjustment ASME	psi	15-725	15-725	15-725	15-725	15-725	15-435

¹Type 812 with the option SHORT for the pressure range 0,2 to 6 bar also available as short version

²Flow coefficients for blow-off pressures > 4,0 bar

³Flow coefficients for blow-off pressures > 7,0 bar

⁴Rated slope value for D/G in scfm/psia

■ MAIN DIMENSIONS, INSTALLATION DIMENSIONS

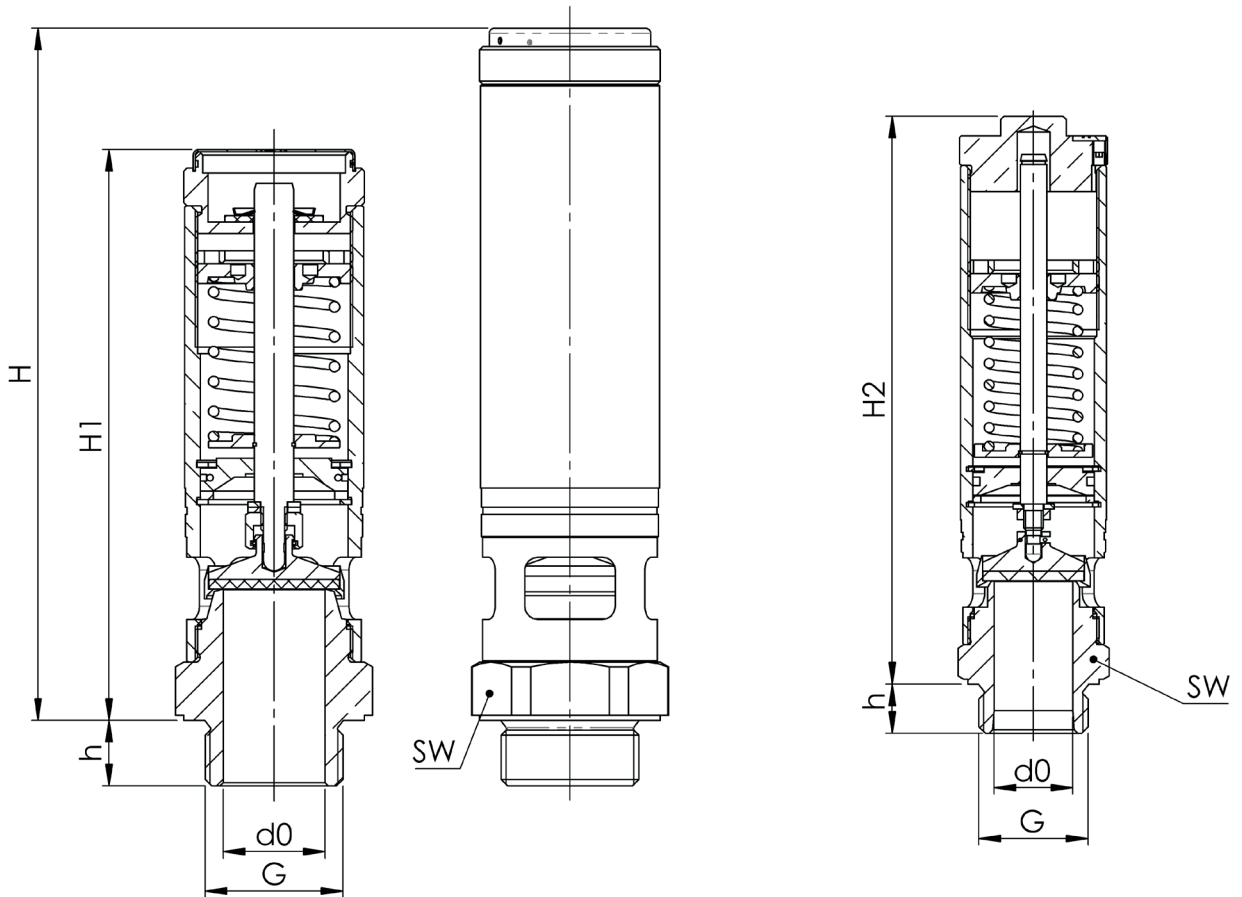

Series	Valve version	Medium	Lifting device	Nominal diameter DN	Connection type		Connection size		Seal	Options	Set pressure	Quantity
					Inlet	Outlet	Inlet	Outlet				
812	s	G	K	40	m	–	40	–	FKM		5,0	3
812	s	G	K	32	m	–	32	–	NBR	SHORT	3,5	2
812	s	G	K			–		–				
812	s	G	K			–		–				

■ PROPERTIES

GOX	Especially for gaseous O2 applications by employment of specific materials including oil- and grease free production process	<input type="checkbox"/>	P03	Galvanically nickel-plated finish	<input type="checkbox"/>
P01	Oil- and grease-free production	<input type="checkbox"/>	P04	Chrome-plated finish	<input type="checkbox"/>
P02	Chemically nickel-plated finish	<input type="checkbox"/>			<input type="checkbox"/>

■ CERTIFICATES / APPROVALS

C01	Factory certificate acc. DIN EN 10204 2.2 (WKZ 2.2)	<input type="checkbox"/>	C06	ATEX evaluation acc. to 2014/34/EU	<input type="checkbox"/>
C02	Test certificate acc. DIN EN 10204 3.1 (WPZ 3.1)	<input type="checkbox"/>	C07	SIL evaluation relating to IEC 61508-2	<input type="checkbox"/>
C03	Material test certificate acc. DIN EN 10204 3.1 (MPZ 3.1) (pressure retaining part)	<input type="checkbox"/>	C09	Seat tightness test with helium, leak detection method under vacuum incl. Factory Inspection Certificate 3.1 acc. to DIN EN 10204	<input type="checkbox"/>
C04	TÜV/DEKRA individual inspection acc. EN 10204 3.2 (TÜV/DEKRA-APZ)	<input type="checkbox"/>	C10	Certificate of oil- and grease free production	<input type="checkbox"/>
C05	Manufacturer certification (FDA, USP 3, 3-A, ...), Please indicate description of certificate:	<input type="checkbox"/>	C11	Certification of the production process especially for gaseous oxygen applications by employment of specific materials	<input type="checkbox"/>

■ ADMISSIONS / ACCREDITATIONS

AA1	EC Type examination acc. to Directive 2014/68/EU	<input type="checkbox"/>	AK1	Det Norske Veritas (DNV) type approval	<input type="checkbox"/>
AA2	TÜV component test acc. to VdTÜV specification sheet SV 100	<input type="checkbox"/>	AK2	Lloyd's Register (LR) type approval	<input type="checkbox"/>
AA3	Certification acc. to ASME Boiler and Pressure Vessel Code, Section VIII.Div 1 (ASME)	<input type="checkbox"/>	AK3	American Bureau of Shipping (ABS) type approval	<input type="checkbox"/>
AA4	EAC - certificate/declaration with passport for the valve and laser marking of the valve	<input type="checkbox"/>	AK4	Bureau Veritas (BV) type approval	<input type="checkbox"/>
AA5	Manufacture License of Special Equipment People's Republic of China (ML)	<input type="checkbox"/>	AK5	Russian Maritime Register of Shipping (RMRS) type approval	<input type="checkbox"/>
AA6	Certification acc. to. Korean Gas Safety Corporation (KGS) ³	<input type="checkbox"/>	AK6	Registro Italiano Navale (RINA) type approval	<input type="checkbox"/>
AA7	Registration according to Canadian Registration Number (CRN) ⁴	<input type="checkbox"/>	AL	Individual inspection by notified body inspector – (body to be indicated):	<input type="checkbox"/>
AA8	Certification according to "Deutsche Bahn"	<input type="checkbox"/>			

³KGS only in combination with ASME | ⁴CRN only in combination with ASME

■ ENQUIRY

sales@pcl-usa.com

Series 812: Blowing-off rates at 10% above set pressure							
Nominal diameter DN		15	20	25	32	40	50
Set pressure bar		d0 = 14 mm	d0 = 20 mm	d0 = 24 mm	d0 = 31 mm	d0 = 31 mm	d0 = 48 mm
		l	l	l	l	l	l
Air l Nm³/h	0,2	57,3	147,0	211,7	353,2	353,2	662,2
	0,5	100,3	220,2	317,1	529,1	529,1	926,9
	1,0	148,5	320,9	462,2	771,1	771,1	1382,7
	1,5	196,5	422,4	608,2	1014,7	1014,7	1852,6
	2,0	246,1	522,8	752,8	1256,0	1256,0	2334,0
	2,5	292,7	621,5	894,9	1493,1	1493,1	2760,6
	3,0	340,6	722,7	1040,7	1736,4	1736,4	3194,6
	3,5	389,8	826,6	1190,3	1985,9	1985,9	3636,1
	4,0	436,0	924,5	1331,3	2221,2	2221,2	4085,1
	4,5	480,4	1018,7	1466,9	2447,4	2447,4	4541,5
	5,0	524,9	1112,9	1602,5	2673,7	2673,7	4967,8
	5,5	569,3	1207,0	1738,1	2899,9	2899,9	5388,2
	6,0	613,7	1301,2	1873,7	3126,1	3126,1	5808,5
	6,5	658,1	1395,4	2009,3	3352,3	3352,3	6228,9
	7,0	702,5	1489,5	2144,9	3578,6	3578,6	6649,2
	7,5	746,9	1583,7	2280,5	3804,8	3804,8	5815,3
	8,0	791,3	1677,9	2416,1	4031,0	4031,0	6161,1
	8,5	835,7	1772,0	2551,7	4257,3	4257,3	6506,9
	9,0	880,1	1866,2	2687,3	4483,5	4483,5	6852,6
	9,5	924,5	1960,3	2822,9	4709,7	4709,7	7198,4
	10,0	969,0	2054,5	2958,5	4936,0	4936,0	7544,2
	11,0	1057,8	2242,8	3229,7	5388,4	5388,4	8235,7
	12,0	1146,6	2431,2	3500,9	5840,9	5840,9	8927,3
	13,0	1235,4	2619,5	3772,1	6293,4	6293,4	9618,8
	14,0	1324,2	2807,8	4043,3	6745,8	6745,8	10310,4
	15,0	1413,1	2996,2	4314,5	7198,3	7198,3	11001,9
	16,0	1501,9	3184,5	4585,7	7650,8	7650,8	11693,5
	17,0	1590,7	3372,8	4856,9	8103,2	8103,2	12385,0
	18,0	1679,5	3561,2	5128,1	8555,7	8555,7	13076,6
	19,0	1768,4	3749,5	5399,3	9008,1	9008,1	13768,1
	20,0	1857,2	3937,8	5670,5	9460,6	9460,6	14459,7
	21,0	1946,0	4126,1	5941,7	9913,1	9913,1	15151,2
	22,0	2034,8	4314,5	6212,9	10365,5	10365,5	15842,8
23,0	2123,6	4502,8	6484,0	10818,0	10818,0	16534,3	
24,0	2212,5	4691,1	6755,2	11270,5	11270,5	17225,9	
25,0	2301,3	4879,5	7026,4	11722,9	11722,9	17917,4	
26,0	2390,1	5067,8	7297,6	12175,4	12175,4	18609,0	
27,0	2478,9	5256,1	7568,8	12627,9	12627,9	19300,5	
28,0	2567,7	5444,5	7840,0	13080,3	13080,3	19992,1	
29,0	2656,6	5632,8	8111,2	13532,8	13532,8	20683,6	
30,0	2745,4	5821,1	8382,4	13985,2	13985,2	21375,2	
32,0	2923,0	6197,8	8924,8	14890,2	14890,2		
34,0	3100,7	6574,4	9467,2	15795,1	15795,1		
36,0	3278,3	6951,1	10009,6	16700,0	16700,0		
38,0	3456,0	7327,8	10552,0	17605,0	17605,0		
40,0	3633,6	7704,4	11094,4	18509,9	18509,9		
42,0	3811,2	8081,1	11636,8	19414,8	19414,8		
44,0	3988,9	8457,7	12179,2	20319,7	20319,7		
46,0	4166,5	8834,4	12721,6	21224,7	21224,7		
48,0	4344,2	9211,1	13263,9	22129,6	22129,6		
50,0	4521,8	9587,7	13806,3	23034,5	23034,5		

Series 812: Blowing-off rates at 10% above set pressure							
Nominal diameter DN		15	20	25	32	40	50
		d0= 0,551 inch (14 mm)	d0= 0,787 inch (20mm)	d0= 0,945 inch (20mm)	d0= 1,220 inch (31mm)	d0= 1,220 inch (31mm)	d0= 1,890 inch (48mm)
Set pressure psi(g)		l	l	l	l	l	l
Air l	15	110,8	226,1	325,5	543,1	543,1	984,8
SCFM	30	161,6	329,8	474,8	792,2	792,2	1436,5
	40	198,8	405,8	584,4	974,9	974,9	1767,8
	50	236,1	481,8	693,9	1157,6	1157,6	2099,1
	60	273,4	557,9	803,4	1340,3	1340,3	2430,4
	70	310,6	633,9	912,9	1523,0	1523,0	2761,6
	87	374,0	763,2	1099,0	1833,6	1833,6	3324,8
	90	385,2	786,0	1131,9	1888,4	1888,4	3424,2
	100	422,4	862,1	1241,4	2071,1	2071,1	3755,5
	110	459,7	938,1	1350,9	2253,8	2253,8	4086,7
	120	496,9	1014,2	1460,4	2436,5	2436,5	4418,0
	130	534,2	1090,2	1569,9	2619,2	2619,2	4749,3
	140	571,5	1166,2	1679,4	2801,9	2801,9	5080,6
	150	608,7	1242,3	1788,9	2984,6	2984,6	5411,8
	160	646,0	1318,3	1898,4	3167,3	3167,3	5743,1
	170	683,2	1394,4	2007,9	3350,0	3350,0	6074,4
	180	720,5	1470,4	2117,4	3532,7	3532,7	6405,7
	190	757,8	1546,5	2226,9	3715,4	3715,4	6736,9
	200	795,0	1622,5	2336,4	3898,1	3898,1	7068,2
	210	832,3	1698,6	2445,9	4080,8	4080,8	7399,5
	220	869,6	1774,6	2555,4	4263,5	4263,5	7730,8
	230	906,8	1850,6	2664,9	4446,2	4446,2	8062,1
	240	944,1	1926,7	2774,4	4628,9	4628,9	8393,3
	250	981,3	2002,7	2883,9	4811,6	4811,6	8724,6
	260	1018,6	2078,8	2993,4	4994,3	4994,3	9055,9
	270	1055,9	2154,8	3102,9	5177,0	5177,0	9387,2
	280	1093,1	2230,9	3212,5	5359,7	5359,7	9718,4
	290	1130,4	2306,9	3322,0	5542,4	5542,4	10049,7
	300	1167,6	2383,0	3431,5	5725,1	5725,1	10381,0
	320	1242,2	2535,0	3650,5	6090,5	6090,5	11043,5
	340	1316,7	2687,1	3869,5	6455,8	6455,8	11706,1
	360	1391,2	2839,2	4088,5	6821,2	6821,2	12368,6
	380	1465,7	2991,3	4307,5	7186,6	7186,6	13031,2
	400	1540,3	3143,4	4526,5	7552,0	7552,0	13693,7
	420	1614,8	3295,5	4745,5	7917,4	7917,4	14356,3
	435	1670,7	3409,6	4909,8	8191,5	8191,5	14853,2
	460	1763,8	3599,7	5183,5	8648,2	8648,2	
	480	1838,4	3751,8	5402,5	9013,6	9013,6	
	500	1912,9	3903,8	5621,5	9379,0	9379,0	
	550	2099,2	4284,1	6169,1	10292,5	10292,5	
	600	2285,5	4664,3	6716,6	11206,0	11206,0	
	650	2471,8	5044,5	7264,1	12119,5	12119,5	
	700	2658,1	5424,7	7811,6	13032,9	13032,9	
	725	2751,3	5614,9	8085,4	13489,7	13489,7	